



Operator's and Service Manual

HUPS-500



Mfg. By: FUJIYAMA POWER SYSTEMS LIMITED

This manual offers important information and suggestions with respect to installation, safety, precautions, troubleshooting and other general information. Please read this manual carefully before operating the product and pay attention to the safety recommendations in it.

The purpose of this manual is to provide the general control operation and fault information to the users. Refer equipment manufacturer's product support manuals for important safety precautions.

Abbreviations:

List of Abbreviations used in the manual: Manufacturers applying this control are respectfully advised that it is their responsibility to employ competent persons to carry out any installation work in the interests of good practice and safety. It is essential that the utmost care is taken with the application of this control device.

Abbreviations	Descriptions
A	Ampere
V	Voltage
LCD	Liquid Crystal Display
LED	Light Emitting Diode
SOC	State of charging
SNMP	Simple Network Management Protocol
ESD	Electro Static Discharge
AC	Alternating Current
DC	Direct Current

Table of Contents

S. No.	Index	Page
1.	Important Safety Information	4
1.1	Instructions	4
1.2	Precautions when working with Batteries	5
1.3	Mechanical Safety	5
1.4	Unit Location	5
2.	Getting Started	6
2.1	About this Manual	6
2.2	HUPS Overview	6
2.2.1	Test Equipment	7
2.2.2	Receipt of system	8
2.2.3	Handling of the system	8
2.2.4	Where to install	8
2.2.5	Installation Procedure	9
2.2.6	Operation and Commissioning	9
2.2.6.1	Front Display Panel	11
2.2.6.2	Alarms	12
2.2.6.3	Display Indication module led indication details	14
2.2.6.4	Block Diagram	17
2.2.6.5	Flow chart of Display Parameters	19
2.2.6.6	Wiring Layout	19
3.	Solar Module Installation & Troubleshooting Instruction	20
3.1	540W Solar Module Specification	20
3.2	Installation Material	22
3.3	Tools Required for Installation	22

3.4	Points to ensure before installation	22
3.5	Mechanical Installation Mounting Methods	22
3.6	Method of Self-Installation	22
3.7	Mounting Locations	23
3.8	Assembly Part	24
3.9	Assembling Solar Panel Structure	24
3.10	Assembling Solar Structure and Module	24
3.11	Installing the wall mount structure	25
3.12	How the stainless steel fixings work	26
3.13	Points to ensure after installation	26
3.14	General Assembly of Solar Panel	27
3.15	I-V curve	28
4.	Troubleshooting	29
4.1	Flow chart of Troubleshooting	29
6.	CONTROL ADJUSTMENT AND SERVICE	35
6.1	Module Removal/Replacement	35
7.	List of Serviceable Parts	36
8.	Testing Points and Testing Procedure	36
9.	Periodical Maintenance Check	38
10.	Technical Specifications	39

1. IMPORTANT SAFETY INFORMATION

1.1 Instructions

This manual contains important instructions that should be followed during installation and maintenance of the system and batteries.

This manual contains important safety, installation and operating instructions. The following symbols are used throughout this manual to indicate potentially dangerous conditions or mark important safety instructions.



WARNING: Indicates a potentially dangerous condition of extreme caution when performing this task.



CAUTION: Indicates a critical procedure for safe and proper operation of the system



NOTE: Indicates a procedure or function that is important for safe and proper operation of the controller.



CAUTION: The handling, installation & maintenance of the battery associated with this equipment, must be done in accordance with the instructions & safety precautions given by the ultracap/battery manufacturer.



CAUTION: Installation, maintenance & repair of the equipment should be undertaken by trained, experienced and authorized by service personnel or electrical personnel.



CAUTION: Please read the installation procedure before installing the system.

ELECTRICAL SHOCK CAN CAUSE SEVERE PERSONAL INJURY OR DEATH

- Remove electric power before removing protective shields or touching electrical equipment. Use rubber insulating mats placed on dry wood platforms over floors that are metal or concrete when around electrical equipment. Do not wear damp clothing (particularly wet shoes) or allow the skin surface to be damp when handling electrical equipment. Do not wear jewelry. Jewelry can short out electrical contacts and cause shock or burning.
- Use extreme caution when working on electrical components. High voltages can cause injury or death.

1.2 Precautions when working with Batteries:



Electrical Hazard: Do not make contact with both of the battery terminals simultaneously with metal parts like screwdrivers & spanners.

Sparking may occur during connection of battery cables to battery terminals.

1. Use cables which are provided with the unit to connect batteries. Do not extend the length of these cables.
 - a. Connect the red cable to the Positive (+) battery terminal.
 - b. Connect the black cable to the Negative (-) battery terminal.
2. Never smoke or make a spark or flame in the vicinity of the battery.
3. Do not drop a metal tool on the battery. The resulting spark or short-circuit on the battery or other electrical part may cause an explosion.
4. Remove personal metal items such as rings, bracelets, necklaces and watches when operating with a battery. Failure to do so may cause a short circuit and very high temperature, which can melt metal items and burn your skin.

See technical specification for battery type and capacity.

1.3 Mechanical Safety

- This unit or parts of the unit may get very hot during normal operation, use care when working nearby.
- Do not expose equipment to rain or snow. Always install in a clean, dry location.
- Do not operate equipment if it has received a sharp blow, been dropped, or otherwise damaged in any way.
- Do not disassemble this unit. Incorrect re-assembly may result in a risk of electric shock or fire.

1.4 Unit Location

- Allow at least 3 inches of free space on all vented surfaces for proper cooling.
- Allow sufficient clearance to open the front panel for servicing.
- Do not operate this unit in a closed-in area or restrict ventilation in any way.
- Do not set any battery on top of this unit.
- The system is rack mounted.

KEEP THIS MANUAL FOR EASY REFERENCE

2. GETTING STARTED:

2.1 About This Manual :

This manual provides operating, troubleshooting and repairing information regarding the HUPS (Hybrid Charge Control Unit), Solar Photovoltaic Modules.

Battery service instructions are available in the battery service manual.

This manual contains basic (generic) wiring diagrams and connection details that are included to help in troubleshooting. Service personnel must use the actual wiring diagram and connection details shipped with each unit.

Read Safety Information discussed above carefully and observe all precautions in this manual.

2.2 HUPS Overview:

FRONT VIEW



TOP VIEW

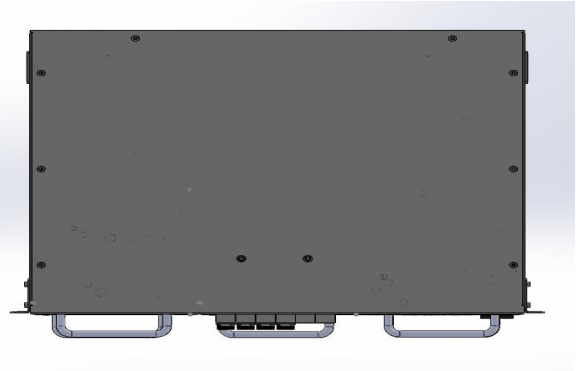

BACK VIEW



SIDE VIEW

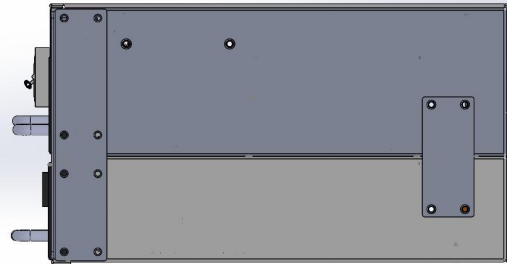

BACK VIEW TERMINAL DETAILS

HUPS is a Hybrid power supply system which uses Solar Photovoltaic power to charge the battery and run the AC load. It also includes a high frequency Grid charger.

HUPS is an innovative as well as eco-friendly AC power solution that provides power to Battery and external DC equipment. It is designed to be installed with an external battery.

- Do not operate this system in direct sunlight, in contact with fluids, or where there is excessive dust or humidity.
- Be sure the air vents on the system are not blocked. Allow adequate space for proper ventilation.
- Connect the AC Mains power cable directly to the distribution board.
- The model and serial numbers are located on a small plate at the front panel.
- Always recycle used batteries.
- Recycle the package materials or save them for reuse.

Features:

- Solar and Grid charging option.
- Modular, Hot Pluggable Design.
- Battery Charger Current Limiting.
- 2 Rectifier+1 Inverter + 1 MPPT Module Positions.
- Prioritize solar power over grid power.
- LCD and LED monitoring.
- RS485 port for external communication.
- Eco-friendly.
- Lithium Battery charging compatible.
- Electronic protection:
 1. Solar Reverse Protection
 2. Solar High Voltage & Current
 3. Battery Reverse.
 4. Battery Over Voltage and Current
 5. Load Over Voltage and Current
 7. Short circuit
 8. Protection against battery Discharge (During night time)
 9. Deep Discharge Battery Recovery
 10. Mains and Solar Surge Protection .

2.2.1 Test Equipment

To perform the test procedures in this manual, the following test equipment must be available,

- True RMS meter for accurate measurement of AC and DC voltages. Fluke models are good choices.
- Grounding wrist strap to prevent circuit board damage due to electrostatic discharge (ESD).
- True RMS Clamp meter for measuring AC & DC current.
- Variac
- Load Test Panel



CAUTION: Incorrect service or replacement of parts can result in severe personal injury or death, and/or equipment damage. Service persons must be qualified to perform electrical and mechanical service.

2.2.2 Receipt of System

When the system is received, please carry out a visual check for any damage during transportation. Check the packages against the shipping documents.

If the package shows visible signs of tampering, the receipt should state necessary reservations (e.g. “cases broken”, “contents lacking”, “cartons opened with signs of pilferage”).

If possible, weigh the packages to determine differences between declared and actual weights. Document any discrepancies on the delivery note/receipt.



CAUTION: Please immediately contact Service person, Dealer or Transport agency for assistance if the following condition occurred :

- any damage observed, either external or internal.
- any accessory is missing or damaged.

2.2.3 Handling of the system

Refer following details for unpacking and handling of the system.

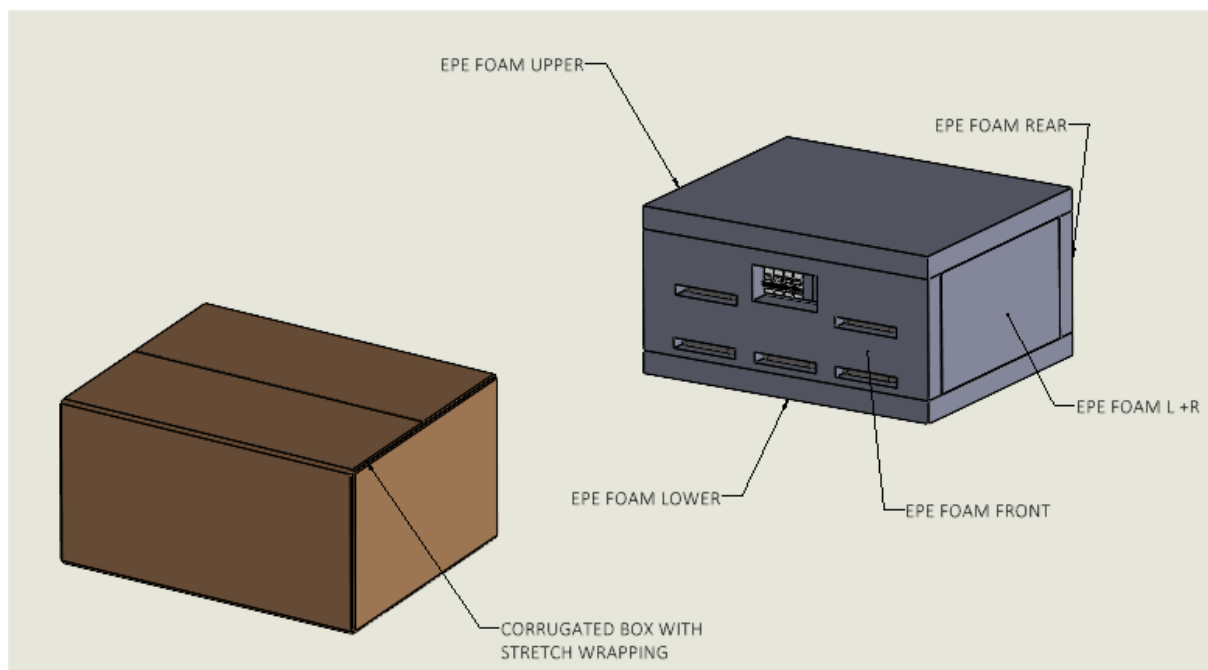

2.2.4 Where to install

The system should be installed in a location that meets the following requirements:

1. HUPS must be installed in a dry & clean room. To have proper ventilation, the user must ensure enough air exchange in the room.
2. Never install the equipment near liquids or in an excessively damp environment.
3. Avoid using equipment in locations with high humidity, corrosive glasses and dust.
4. This system is a Rack mounted system.

2.2.5 Installation Procedure:

Step-1: System has a rack mounted design, so place it as per the design.

Step-2: Connect the battery terminals to the system such that the positive (+ve) battery terminal should be connected to the Red (+ve) cable of HUPS and the Negative (-ve) battery terminal should be connected to the Black (-ve) cable of HUPS.

Step-3: Connector HUPS system solar input wire to the solar panel through wire which is provided with the system, Marked as SPV. Connect the positive(+ve) Solar Photovoltaic module terminal to the positive(+ve) terminal of HUPS Solar terminal and the negative(-ve) Solar Photovoltaic module terminal to the negative(-ve) terminal of HUPS Solar terminal.

Note: Please first verify the Voc of the Solar Photovoltaic module, it must be according to the rating specified on the system.

Step-4: HUPS has AC Load Socket connect Ac load external which is provided in the Front of the system inverter module

Step-5: Now, connect the AC wire of your system to the Mains outlet.



CAUTION: Plug shall be easily accessible to the socket outlet.

2.2.6 Operation and Commissioning: Hybrid SPV Power supply contains Solar charge controller and switch Mode Power supply (SMPS). This power supply is designed in a way that load requirement is primarily met by SPV module and the remaining by the SMPS. The SMPS may be required for occasional topping up of the batteries in case of unfavourable weather conditions for solar supply. The battery will run the Load only when the input power is not sufficient. When the incoming power is such that it fulfills the load requirement then the excess power will be used in charging the battery.



CAUTION: Do not disconnect the battery wires when the system is ON.

External wire Detail.

Wire Detail	Wire dimension	Wire Size
Battery wire (+Red)	6 mm Square	As per requirement
Battery wire (-Black)	6 mm Square	As per requirement
Mains Line (Red)	2.5 Sq mm Square	As per requirement
Mains Neutral (Black)	2.5 sq mm Square	As per requirement
Earthing (Yellow/ Green)	4 mm Square	As per requirement
Invertor Ac load	250V/6A Cord	As per requirement
SPV (- Brown)	4mm Square	As per requirement
SPV (- Blue)	4mm Square	As per requirement

2.2.6.1 Front Display Panel:

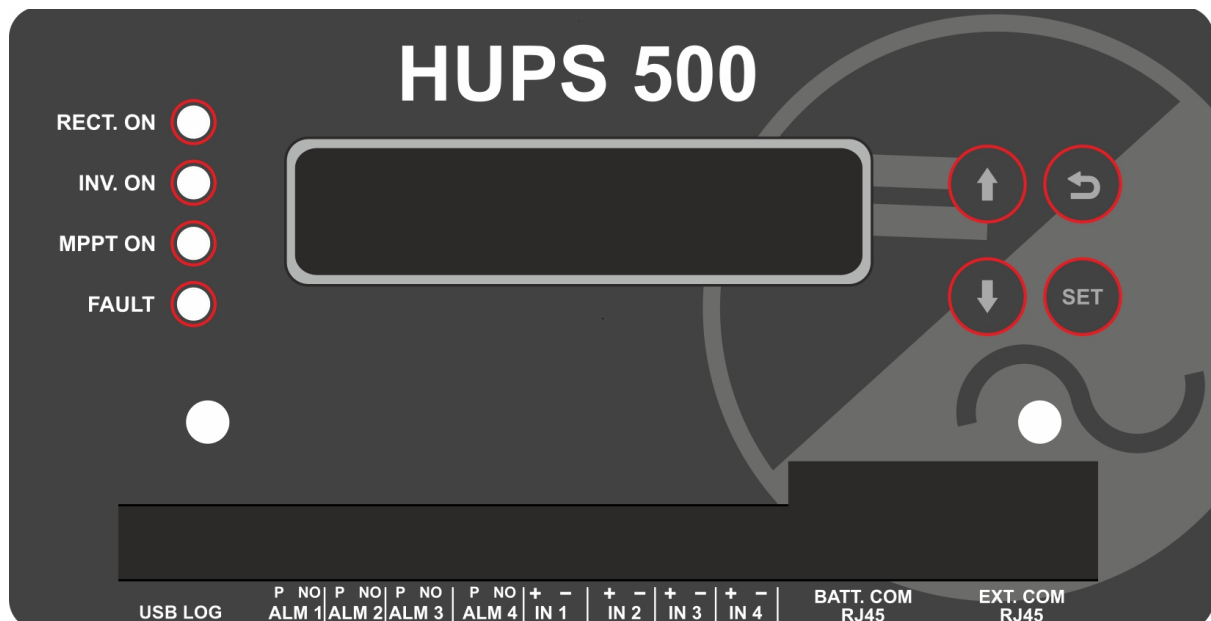

1. LCD Display:

HUPS has a user -friendly LCD panel which shows system parameters like battery voltage, charging current, Load voltage and load current , Solar input voltage , solar input current and fault status.

2.LEDs:

RECT . ON (Green LED): This LED indicates AC Mains condition -

1. Continuous Glowing - AC mains is in specified range (90V to 300V).
2. Continuous OFF - AC input is not available.
3. Continuous OFF - AC input is below from specified range (90V).
4. Continuous OFF - AC input is above specified range (300V).

INVERTER.ON (Green LED): This LED indicates the inverter ON.

MPPT. ON SPV (GREEN LED): This LED indicates that MPPT on..

FAULT (Red LED): This LED in Display indicates Battery Low/Battery High condition.

1. Battery low - 500m sec ON, 1 times then 1sec OFF, (repeat till the fault).

2.Battery high - 500m sec ON, 500m sec OFF-2 times then 1sec OFF, (repeat till the fault).

3.SWITCHES AT FRONT DISPLAY:

MENU: This is used to enter in setting parameters. Also used to select the desired parameter (As an ENTER switch).

UP: This is used for UP scrolling of Display Parameters.

DOWN: This is used for DOWN scrolling of Display Parameters.

EXIT: This is used to exit or back from the Main Menu and By pressing this switch for at least 2 sec, System will be OFF as Emergency mode.

4. Communications Port

BATT.COMM : It shows the battery parameters like this BV , SOH,SOC, TEMP.

EXT. COMM: It shows the system parameters like output voltage, output current etc.

5. ALARMS

PFC ALARM

RELAY ALARM	
ALARM -1	RECTIFIER FAIL
ALARM -2	BATTERY LOW
ALARM -3	MPPT FAIL
ALARM -4	INVERTER FAIL

INPUT SIGNAL

INPUT ALARM SIGNAL	
I/P-1	ALARM FOR FIRE or SMOKE
I/P-2	DOOR OPEN ALARM FOR RACK
I/P-3	ALARM FOR RACK TEMP.
I/P-4	Configurable

NOTE -When input signal will be active low then alarm comes on display and alarm relay

LED INDICATION OF RECTIFIER MODULE

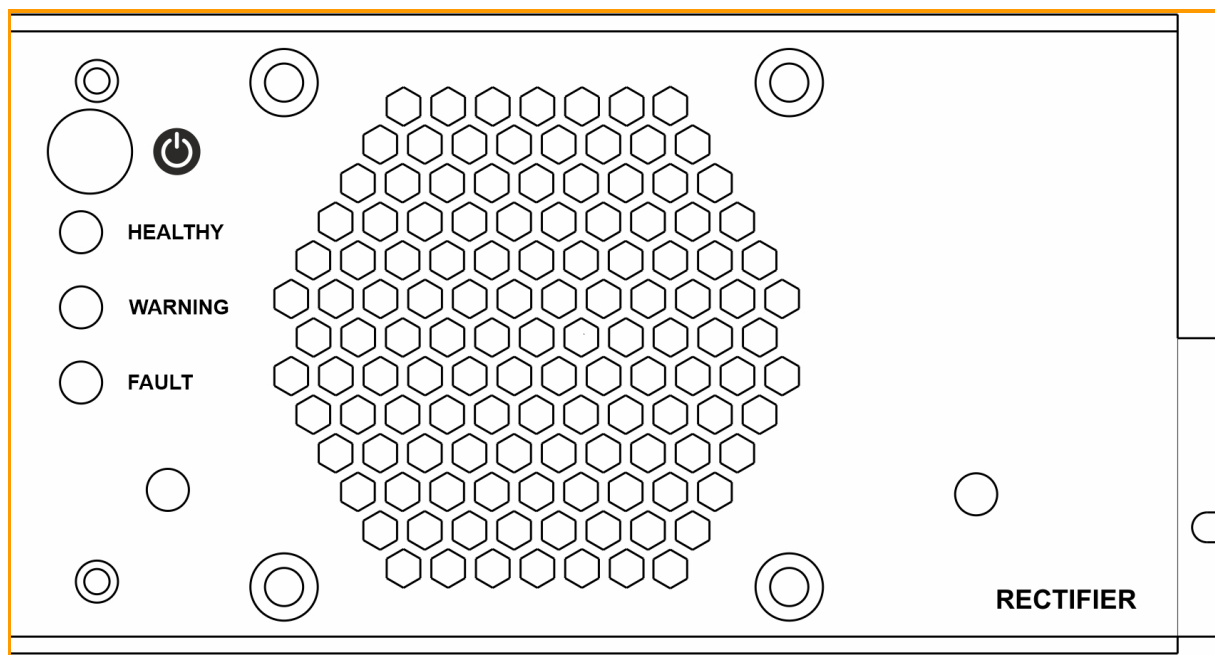

Healthy (Green LED): This LED indicates AC Mains condition -

- 1.Continuous Glowing - AC mains is in specified range (90V to 300).
- 2.Continuous OFF - AC input is not available.
- 3.Continuous OFF AC input is below the specified range (90V).
- 4.Continuous OFF- AC input is above specified range (300).

RECT FAN Fail (ORANGE LED): This LED indicates the Rectifier Fan Fail.

Major (Red LED): This LED indicates a fault condition.

1. **OVER LOAD** - 500ms ON , 500ms OFF - 3 times then 1 sec OFF , (repeat till the fault).
2. **Output Short Circuit** - 500mSec ON , 500ms OFF - 4 times then 1sec OFF , (repeat till the fault).
- 3 **MAINS LOW** - 500mSec ON , 500mSec OFF - 5 times then 1sec OFF , (repeat till the fault)
4. **MAINS HIGH** - 500ms ON , 500ms OFF - 6 times then 1 sec OFF , (repeat till the fault).
5. **Over Temperature** - 500mSec ON , 500mSec OFF - 7times then 1sec OFF , (repeat till the fault)
6. **Output Low** - 500ms ON , 500ms OFF - 8 times then 1 sec OFF , (repeat till the fault).
7. **Output High** - 500ms ON , 500ms OFF - 9 times then 1 sec OFF , (repeat till the fault).

8. Rectifier Fail - Solid Glow

Switch This switch is used to turn the Rectifier on and off

LED INDICATION MPPT MODULE

Healthy (Green LED): This LED indicates SPV condition -

- 1.Continuous Glowing - Mppt OK
- 2.Continuous OFF - SPV input is not available.

Warning . ON SPV (Amber LED): This LED indicates that the battery is charging on the SPV

Major (Red LED): This LED indicates a fault condition.

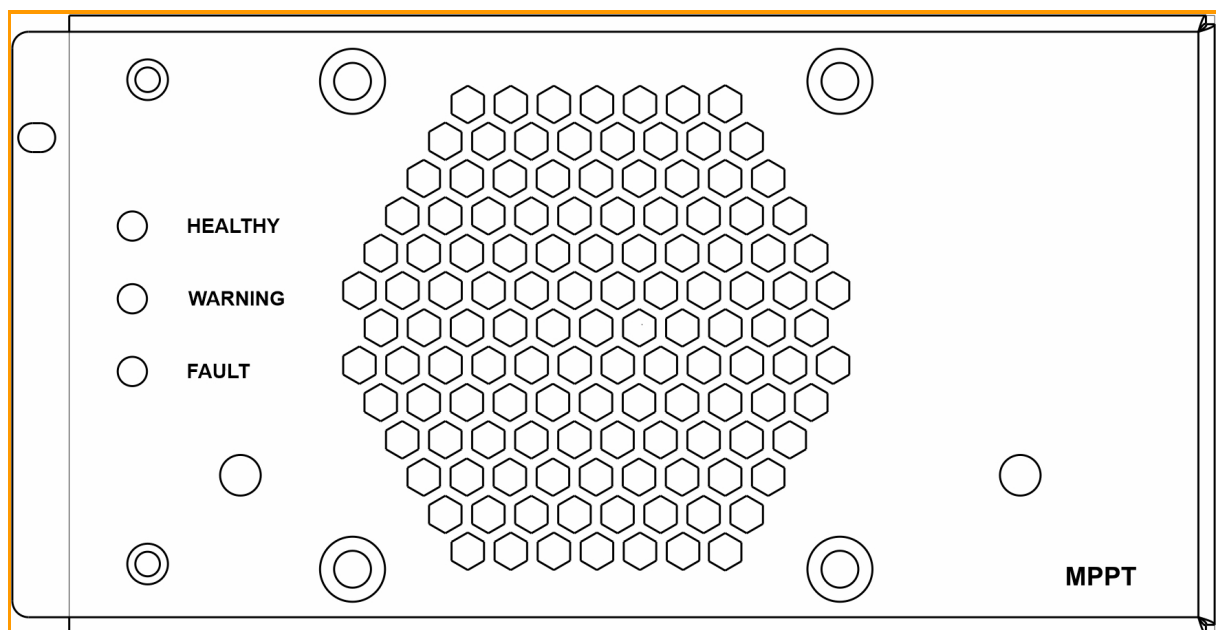

1.OVERLOAD - 500m sec ON, 500m sec OFF - 3 times then 1sec OFF, (repeat till the fault)

2. **Output Short Circuit** - 500m sec ON, 500m sec OFF - 4 times then 1sec OFF, (repeat till the fault)
- 3 **Solar LOW**- 500m sec ON, 500m sec OFF - 5 times then 1sec OFF, (repeat till the fault)
4. **Solar HIGH** - 500m sec ON, 500m sec OFF - 6 times then 1sec OFF, (repeat till the fault)
5. **Over Temperature** - 500m sec ON, 500m sec OFF - 7 times then 1sec OFF, (repeat till the fault)
- 6.**Output LOW** - 500m sec ON, 500m sec OFF - 8 times then 1sec OFF, (repeat till the fault)
7. **Output HIGH** - 500m sec ON, 500m sec OFF - 9 times then 1sec OFF, (repeat till the fault)
8. **MPPT FAIL** - Solid Glow

LED INDICATION OF INVERTER MODULE

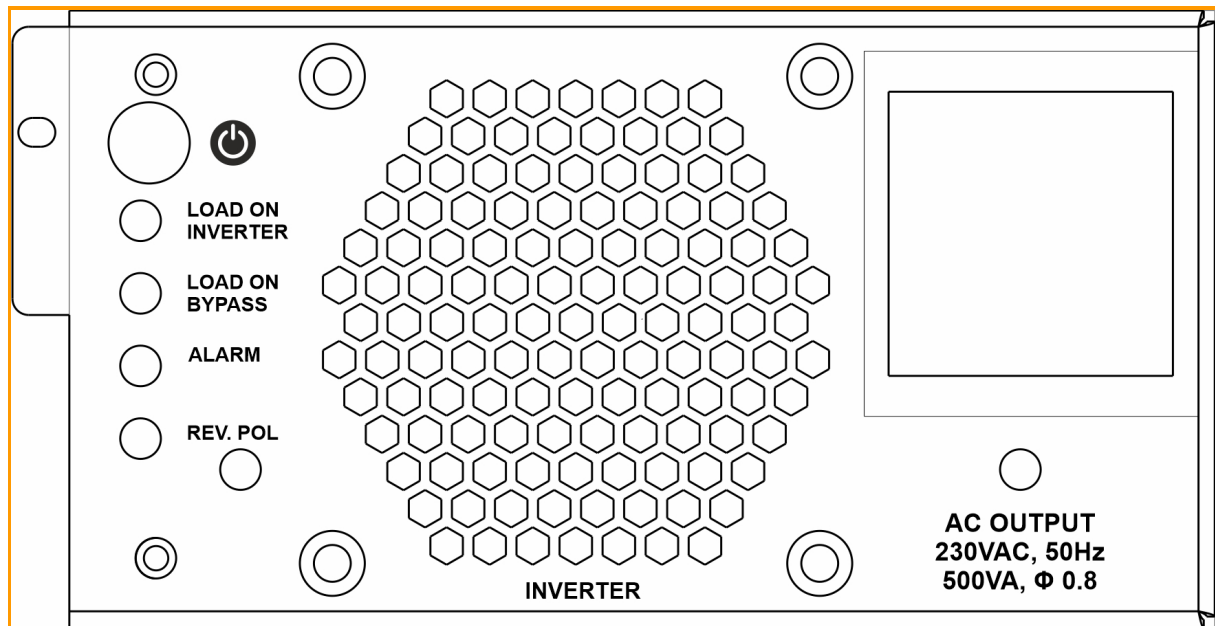

Load on Inverter (Green LED):This LED indicates load on inverter .

Load on Bypass (Amber Led): This LED indicates load on Bypass.

Alarm (Red LED) : This LED indicates alarm condition.

1. **Battery Low** - 500m sec ON, times then 1sec OFF, (repeat till the fault)
2. **Battery High**- 500m sec ON, 500m sec OFF - 2 times then 1sec OFF, (repeat till the fault)
3. **OVERLOAD** - 500m sec ON, 500m sec OFF - 3 times then 1sec OFF, (repeat till the fault)
4. **Output Short Circuit** - 500m sec ON, 500m sec OFF - 4 times then 1sec OFF, (repeat till the fault)
5. **MAINS LOW** - 500m sec ON, 500m sec OFF - 5 times then 1sec OFF, (repeat till the fault)

6. MAINS HIGH - 500m sec ON, 500m sec OFF - 6 times then 1sec OFF, (repeat till the fault)

7. Over Temperature - 500m sec ON, 500m sec OFF - 7 times then 1sec OFF, (repeat till the fault)

8. Output Low - 500m sec ON, 500m sec OFF - 8 times then 1sec OFF, (repeat till the fault)

9 Output High - 500m sec ON, 500m sec OFF - 9 times then 1sec OFF, (repeat till the fault)

10 Inverter OFF - Solid Glow.

2.2.6.2 Display Indication Details:



When the battery is charging by Grid or Solar, This indicates the inverter output voltage frequency load percentage



When the battery is charging by Mains . second line as mains voltage output voltage total output current



When the battery is charging by MPPT first line as solar input voltage solar input current second line as output voltage & output current



When system on by battery & show battery voltage & charging current

PROTECTIONS AND FEATURES:

A. Solar Photovoltaic Reverse Polarity:

Protection against PV reverse connections, No damage to the Solar charge controller. Correct the wrong wiring to resume normal operation.

B. Battery Reverse Polarity: Protection against battery reverse connections, No damage to the Hybrid solar UPS system. Correct the wrong wiring to resume normal operation.

Warning:- Do not connect the reverse battery, when Solar or Mains charger is ON.

C. Battery Over Charging Voltage / Current:

This device has Features to protect batteries from overcharging which can cause damage due to excessive heating. It always limits the charging voltage/current that maintains battery health/Life.

D. Solar High Voltage:

This will protect against High/Low voltage of solar panels. If high solar voltage is applied to the system then it will automatically detect high input solar voltage and disconnect the solar power.

E. Output High voltage and current:

It will protect the load against high voltage and current. If output voltage goes above specified range, It automatically disconnects the load. In over current protection, if the system is turned off and takes 3 attempts to switch on the unit in normal condition at an interval of 10 sec and after fourth attempts, load will disconnect for 30 min. To reconnect the load unit in normal condition, the Load current needs to be reduced.

F. Reverse Current Flow from Battery to Solar Supply:

During late night hours, solar panels try to fetch power from the battery. In HUPS, there is a protection against reverse flow of current from battery to solar panel. This will help to save stored energy in the battery.

G. Deep Discharge Battery Recovery:

If the battery gets deep discharged then HUPS has the ability to charge the battery efficiently.

2.2.6.4 Block Diagram

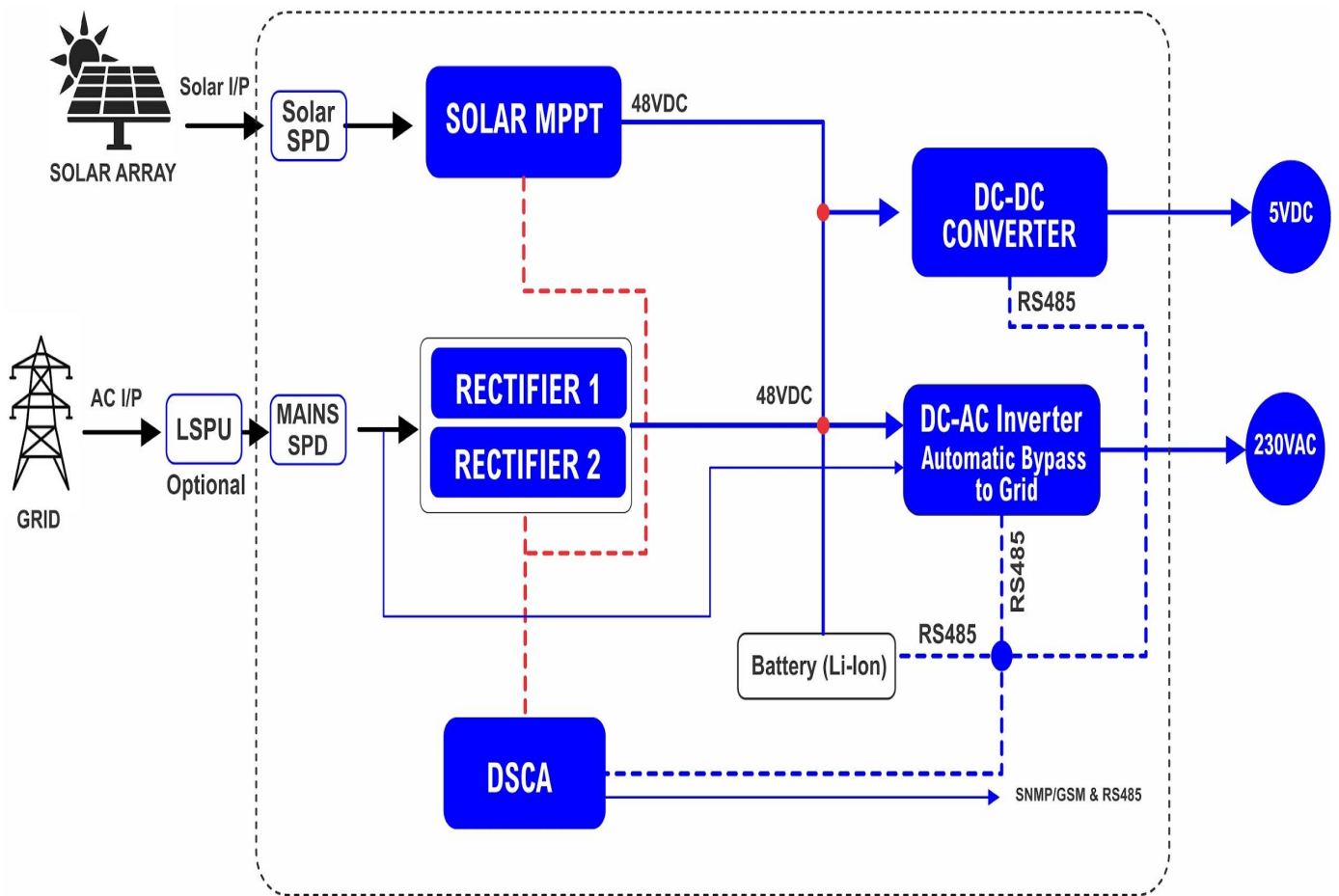

2.2.6.5 Flow chart of Display parameters

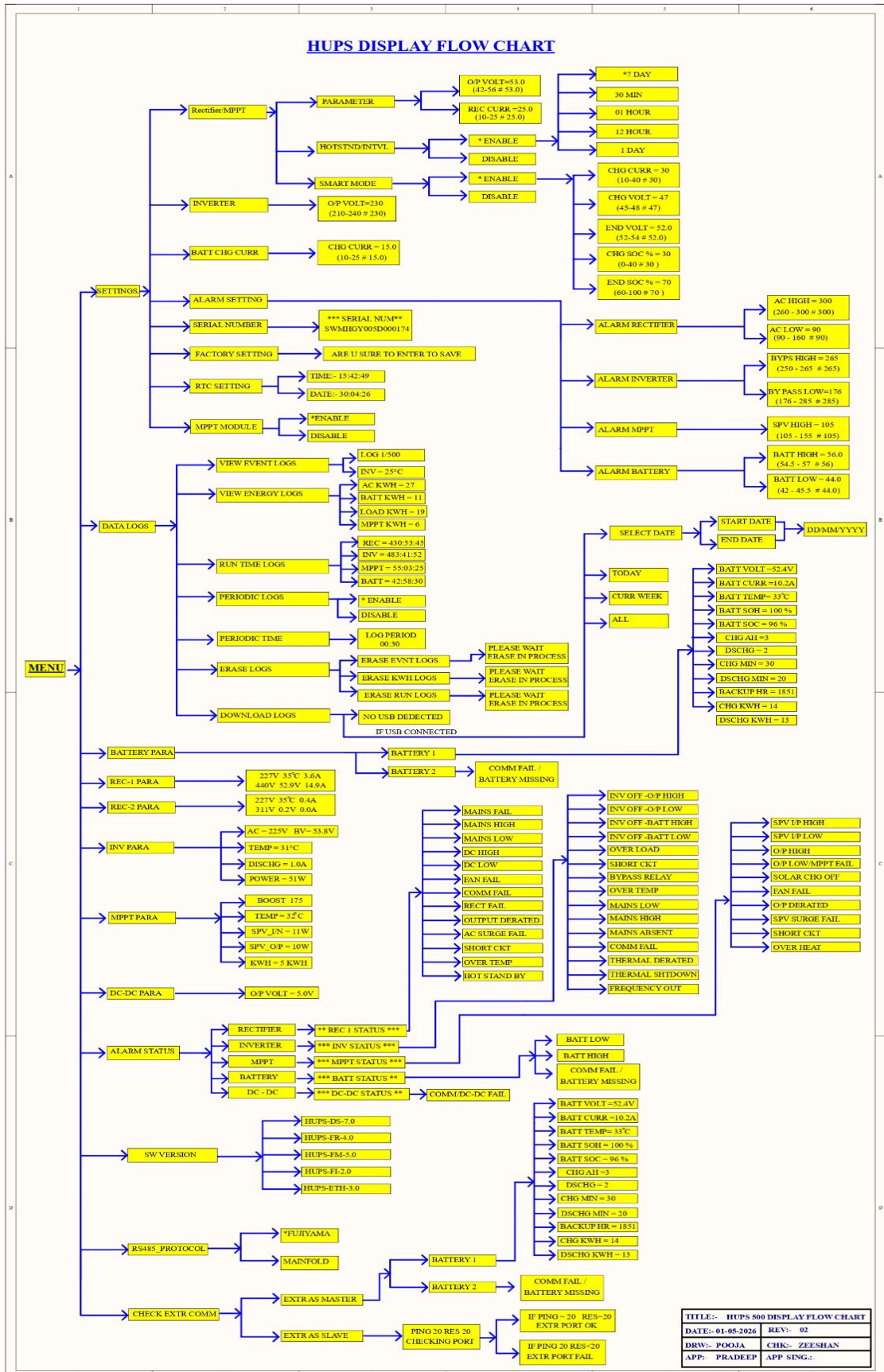

2.2.6.6 Wiring Layout:

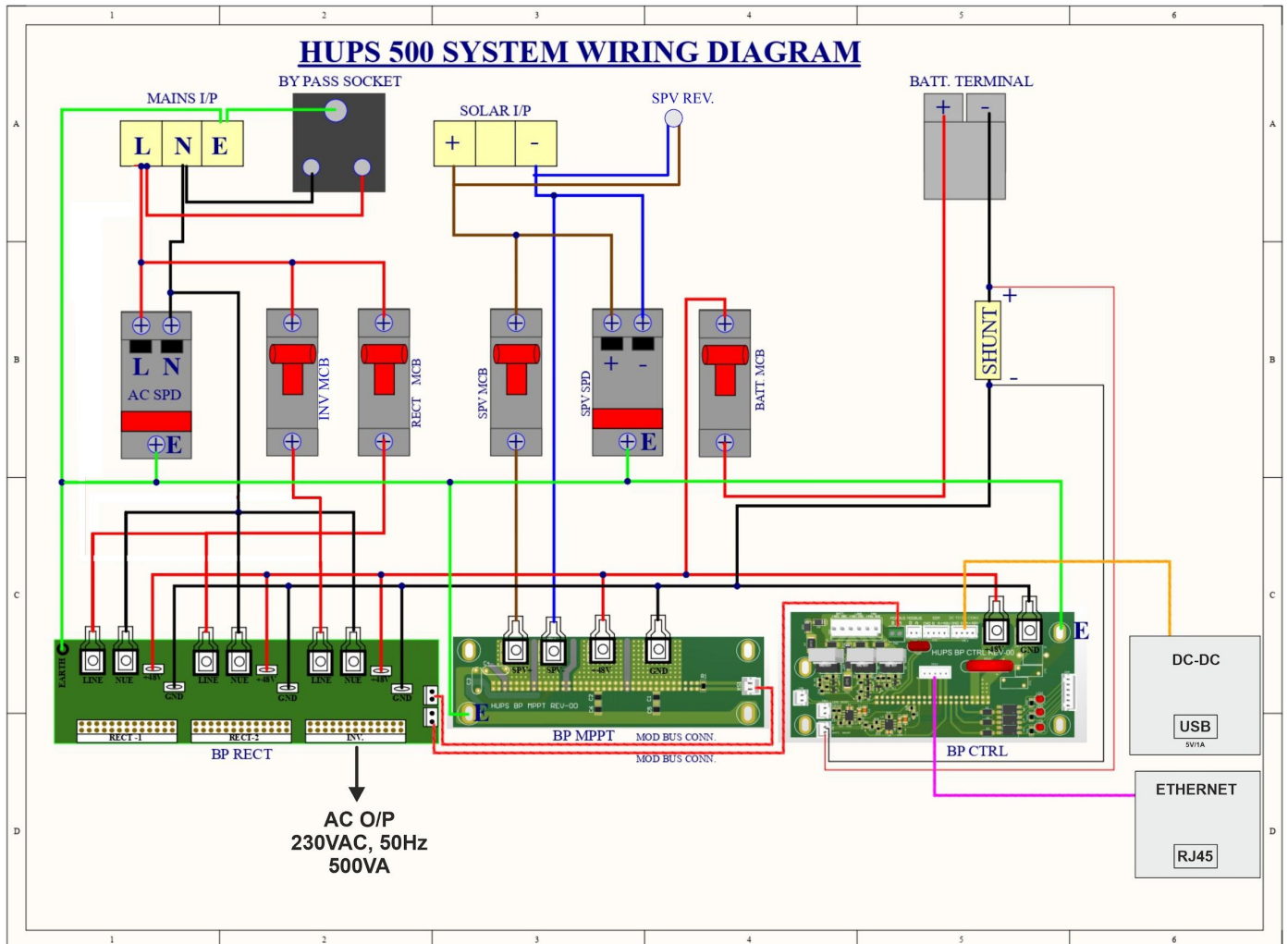

3. SOLAR MODULE INSTALLATION & TROUBLESHOOTING INSTRUCTIONS:

3.1 540W Solar Module Specification:

S.NO.	Parameter	Specification
1.	Maximum Power (Pmax)	540W
2.	Open Circuit Voltage(Voc)	49.65V
3.	Operating Voltage (Vmp)	41.8V
4.	Short Circuit Current (Isc)	14A
5.	Operating Current (Imp)	13.11A
6.	Module Efficiency	20.75%
7.	Power Tolerance (±)	3%

8.	Maximum System Voltage	1500 Vdc
9.	Maximum Series Fuse (Recommended)	20A
10.	Module Frame Dimension	2285x1140x40 mm
11.	Weight	27.5kgs
12.	Operating Temperature	Minus -40° C to plus 85° C
13.	Cell type	10 BB Mono PERC
14.	Cell arrangement	12x6 II 12x6
15.	No. of Cell	144
16.	Front Glass	3.2 mm Low Iron and Tempered glass with ARC coating
17.	Junction Box	IP68,
18.	Cable & Connector	IP68 rated / C4 Compatible

NOTE:- Above specification or dimensions may vary as per tolerance.

3.2 Installation Material:

Please Refer Installation BOM for this.

3.3 Tools Required for Installation:-

1. Compass	5. Screw Driver Set	9. Hammer
2. Multimeter/Clamp Meter	6. Wrench Set	10. Hacksaw Blade
3. Flat Nose Pliers	7. Drill Machine	11. Extra Connecting Wire
4. Wire Cutter	8. Drill Bit	12. Allen Key (12mm 4 inch)

3.4 Points to ensure before installation:

- Ensure all site installation material packages are complete and not damaged as given in the above material list.
- Contact with electrically active parts of the panels, such as terminals, may result in burn and spark.
- Solar Panels produce voltage even when not connected to an electrical circuit or load.
- Industry standard rated specifications are made at conditions of 1000W/m sq. radiance and 25 °C solar cell.
- Keep flammable gasses away from the installation site.

- Keep the module packed in the carton until the time of installation.
- Do not drop the solar module or place weight on a solar module.
- After installation or repair, check if the solar modules are operating properly.
- Low temperature may substantially increase voltage and power.
- Partial shadow may substantially reduce panel and system output power.
- Care must be taken to avoid low tilt angles which may cause dirt to build up on the glass against the frame edge.
- Dirt build-up on the surface of the panel may cause active solar cells to be shaded and electrical performance to be impaired.

3.5. Mechanical Installation Mounting Methods:

- Select the appropriate orientation of the solar module to maximize sunlight exposure (toward south).
- Secure the solar module to the structure by using the factory mounting holes.

3.6. Method of Self-Installation:

Self-Installation of your Solar panel system can be broken down into three (3) basic steps:

- a) System Assembly consists of assembling the pieces provided to form a complete solar panel set.
- b) Solar panel Installation involves suitable mounting locations, finding the solar panel in relation to your surroundings, and physically attaching the solar panel to your structure.
- c) Connecting the solar panel to receiver load consists of connecting your Solar panel with structure, receiver load, earthing etc.

IMPORTANT: Read this manual thoroughly before you start.

WARNING: All solar panel systems must be properly grounded. Improper grounding can result in damage or system performance issues.

This installation requires to:

- Use hand tools such as a drill.
- Determine whether water pipes, electrical wiring and gas lines should not be close to the installation area.
- Use a compass for true south facing.
- Use a ladder to climb structures.

Helpful Hints:-

Key points to remember when installing your Solar panel System:-

- Do not drill any hole until you've confirmed the best location for the solar module.
- For possible periodic removal of dust/bird particles, choose a site that is easily accessible.

- Ensure there are no visible obstructions between the solar panel and your Sun. Keep in mind that trees will grow up and outward and may eventually block the sun rays falling on solar panels.
- The maximum allowable length for Cu coaxial cable connecting the solar panel to your receiver load is 50 feet. Consult with the project leader if the cable will exceed this length.
- Use only FR grade coaxial cable. Using lower grade Cu coaxial cable may result in excessive power loss and poor performance.

Do not install the solar panel:-

- Under power lines
- Where it may be easily tampered with
- Where it is exposed to high winds, during windy or stormy conditions
- Avoid Shadow area

3.7. Mounting Locations:-

Your solar module structure must be mounted on a solid base. To ensure your solar module/structure doesn't move in windy conditions, choose a location where it can be securely fastened. The mounting surface should be rigid and solid.

IMPORTANT:- The solar panel has a turn angle of min. 15 degrees. If you are mounting the solar panel on the side of your house, check the assembled solar panel and mounting pole to easily rotate in the desired azimuth setting. If you can't rotate the solar panel, choose an alternate location.

Key things to remember when choosing a mounting location:-

- The mounting surface should be flat, even and in good condition.
- If you install the solar panel on the roof or side of your house, be sure to attach the bolts into a building stud, rafter or other solid surface.
- When mounting on the roof of your house, use an adequate/approved sealant (for your type of roofing material) around the holes where the base of the universal mount meets the mounting surface. This will prevent the roof from leaking.

3.8. ASSEMBLY PART

At the solar panel install site, hold a compass level and still in the palm of your hand. When the needle stops rotating (dark half of the needle always points north), slowly rotate the body of the compass so that the "S" marking is aligned with the dark half of the needle. This is the direction in which to point your solar panel to receive the sunlight.

3.9. Assembling Solar Panel Structure

Step 1: Ensure the mounting area is plumb before drilling any holes. Hold the base pole with base plate in place on the mounting area. Lock it in place by securely tightening the base pole adjusting Fastener / Bolts.

IMPORTANT: Alignment of the base pole will be difficult if the mounting area is not plumb.

Step 2: Drill holes in the mounting area as per base pole plate hole.

Step 3: Secure the base pole plate with appropriate fastener/nut bolts. Check the mount for movement. An improperly secured mount will affect solar panel damage or system breakage.

Step 4: Slide the Clamp Mount Assembly onto the base pole by loosening the Elevation Pivot Bolt just enough to slide the assembly until it makes contact with the Elevation Pivot Bolt. Tighten the Elevation Pivot Bolt just enough to hold it in place on the base pole head.

Step 5: Loosen the Elevation Adjustment Bolt 1/3 turn from tight on either side of the Clamp Mount Assembly. Tighten the Elevation Adjustment Bolts.

Step 6: Using your compass and select the azimuth setting in the true south face.

Step 7: Loosen the Elevation Adjustment Bolts on either side of the Clamp Mount Assembly. Adjust the elevation Alignment with the scale indicator to true south facing. Finally; lock it in place by securely tightening the elevation Adjustment Bolts.

IMPORTANT: Do not make any further adjustments to the elevation setting from this point onward.

3.10. Assembling Solar Structure and Module

Open your package-After reaching material on site, First you have to open your package and check all material received as per shown list.

- a) **Face the solar module structure in the south direction.** Try to use a wall/flat roof that has no shadow effect from trees and other obstructions in its view. A south-facing is the most ideal direction for a solar panel. Make sure that the solar module is within 30 feet of your connecting load.

Mount the solar module structure- After selecting the place for the solar module mounting structure, you may have to drill holes in your walls and caulk them accordingly with the solar module structure base pole. Make sure there is no important piping, wiring, or other obstructions when making holes in the wall. Make sure all fasteners are fully tight and completely fixed in the wall/flat roof.

- b) **Mount solar panel on structure-** Install solar panel module on its mounting structure carefully and fully tight with module structure with the help of module fastener.
- c) **Run cables from your solar panel to your receiver load –** You may run cable/wire from the solar module to receiver load through flexible conduit pipe. Always try to reduce the distance between the solar module and receiver load for better performance.
- d) **Earthing pit-** First make sure the nearest distance on ground from solar panel to earthing pit/hole. Before drilling in earth make sure that there is mix sand/stone in earth for easy earth pit/hole, avoid the fully stone area for earth pit/hole.

- e) **Earthing**- Connect earthing lead properly from solar module/structure to earthing kit. Remove / scratch the upper coating layer of the solar panel earthing point area for good earthing contact.
- f) **Connection** – After completion of its wiring makes sure its power supply is proper and reaches up to receiver load.

3.11. Installing the wall mount structure:-

First of all, you have to find an appropriate location. Take into account these two requirements:

- The location must allow the correct orientation of the solar panel to the south direction. Use the compass to find true south facing.
- There cannot be any obstacles between the solar panel and the sun rays path.

Take the "base pole" /flat roof wall mount, and attach it to the roof /wall manually. Mark the positions of the future holes on the roof /wall. Now, drill the four holes. Be careful choosing an appropriate diameter .

3.12. How the stainless steel fixings work

Put the four fixings in their holes, and use the hammer and the chisel to fix them. Now take the "Structure" on the roof and screw it to the fixings. Don't forget the washers.

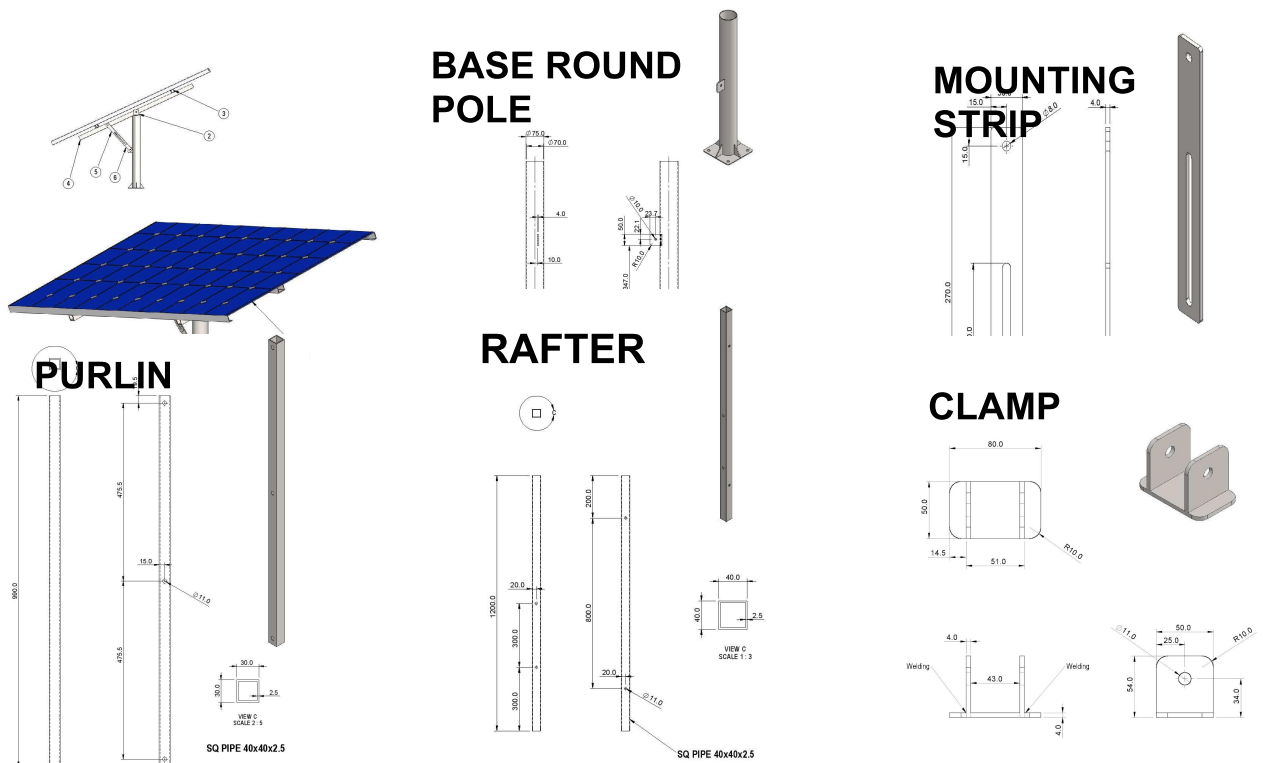

3.13 Points to ensure after installation:

- Ensure all kinds of structure fasteners and nut-bolt are properly tight.
- Ensure all solar module nut-bolts are properly tight with module structure.

- Plug-in the connector tightly and ensure that the wiring properly works.
- Removal of dirt from the front glass can increase output.
- Solar panel connecting wires to the pass through conduit pipe.

3.14 GENERAL ASSEMBLY OF SOLAR PANEL :-

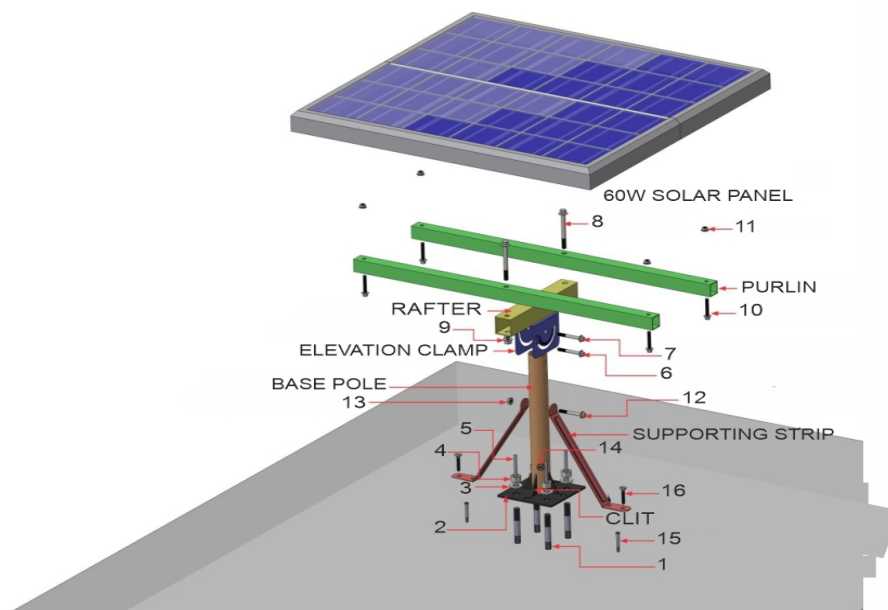

1. FASTENER - M10x75MM
2. BASE PLATE
3. FASTENER WASHER P/L - 12x25MM
4. FASTENER NUT - M10
5. FASTENER PIN - 75MM
6. ELEVATION CLAMP BOLT - M6x55MM (P/L WASHER 6x20MM)
7. ELEVATION CLAMP BOLT - M6x55MM (P/L WASHER 6x20MM)
8. PURLIN RAFTER BOLT - M8x75MM
9. PURLIN RAFTER NUT - M8
10. SOLAR PANEL BOLT - M6x40MM (P/L WASHER 6x20MM)
11. SOLAR PANEL NUT - M6 (P/L WASHER 6x20MM)
12. SUPPORTING STRIP BOLT - M6x55MM (P/L WASHER 6x20MM)
13. SUPPORTING STRIP NUT - M6 (P/L WASHER 6x20MM)
14. GROUND NUT - M6
15. PVC GITTI - 35MM
16. SELF SCREW - 50MM

3.15 I-V Curve

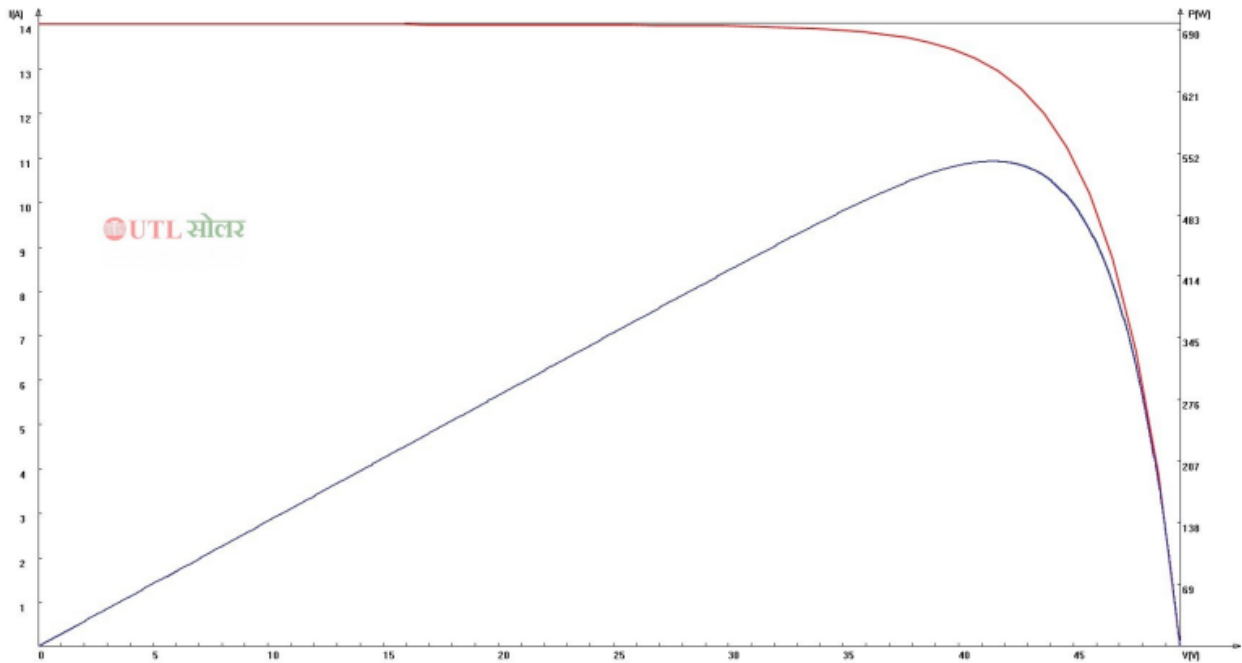

ModuleID: UTL0422GA54000004
Irradiance: 1000.2 W/M2

Company: UTL
MechineName: IV tester

Pmax: 540.490 W
Voc: 49.641 V
Isc: 14.032 A
Vm: 40.536 V
Im: 13.334 A
FF: 77.59%
Rs: 0.294 ohm
Rsh: 512.750 ohm
Eff(Cell): 22.663%
Eff(Mod): 20.749%

CellType: MONO
ProductName: PV Module
TestTime: 13:21:54 04-04-2022

5. TROUBLESHOOTING:

Sr. No.	Fault/ LED indication	Check Points	Solution
---------	-----------------------	--------------	----------

1	a) System not on	<ol style="list-style-type: none"> 1. Check the Battery reverse Led & polarity of Battery Wire Connections to the Battery terminal. 2. Check Battery MCB. 	<ol style="list-style-type: none"> 1. Battery wire must be connected properly (Batt +ve connected to the Batt +ve terminal and Batt. -ve connected to the Batt.-ve terminal in the card. 2. Battery MCB should not OFF.
	b) Overload /Short CKT	<ol style="list-style-type: none"> 1. Connected Load is greater than the specified range. 	<ol style="list-style-type: none"> 1. Reduce the load.
2	a) Battery not charging by SPV (No indication)	<ol style="list-style-type: none"> 1. Check Voc of SPV ,Check Solar Connection, Check polarity of solar connection. Check SPV MCB on the front panel. 	<ol style="list-style-type: none"> 1 Voc voltage of solar must be in the range of 60V-110V. 2. It should be connected to an SPV terminal that may be open, connect it. 3. Check polarity of connector according to marking at SPV terminal.
	b) Battery not charging by SPV (PV Charge indication)	<ol style="list-style-type: none"> 1. Check the wire connection from SPV to Back Panel PCB. 2. Check SPV MCB . 3. Check battery wire connection to the terminal. 	<ol style="list-style-type: none"> 1 Wiring should be according to the wiring diagram. 2. SPV MCB should not OFF. 3. Battery wire must be connected properly.
3	a) Battery not charging by Mains(No Indication)	<ol style="list-style-type: none"> 1. Check mains ON/ OFF . 2. Input AC voltage too low or high . 3. loose connection at Connector. 	<ol style="list-style-type: none"> 1. Mains MCB in ON position . 2. Make sure Input voltage in range (90-300V). 3. Make sure Input Connection and battery connector are properly fitted.
	b) Battery not charging by Mains(mains charging Indication)	<ol style="list-style-type: none"> 1. Check the Mains wire connection on the SPV board. 2. Check AC fuse on Rectifier board. 3. Check battery wire connection to the terminal. 	<ol style="list-style-type: none"> 1. Wiring should be according to the wiring diagram. 2. AC Fuse Should not be blown. 3. Battery wire must be connected properly.

5.1 Flow Chart of Troubleshooting:

Condition: System Not ON

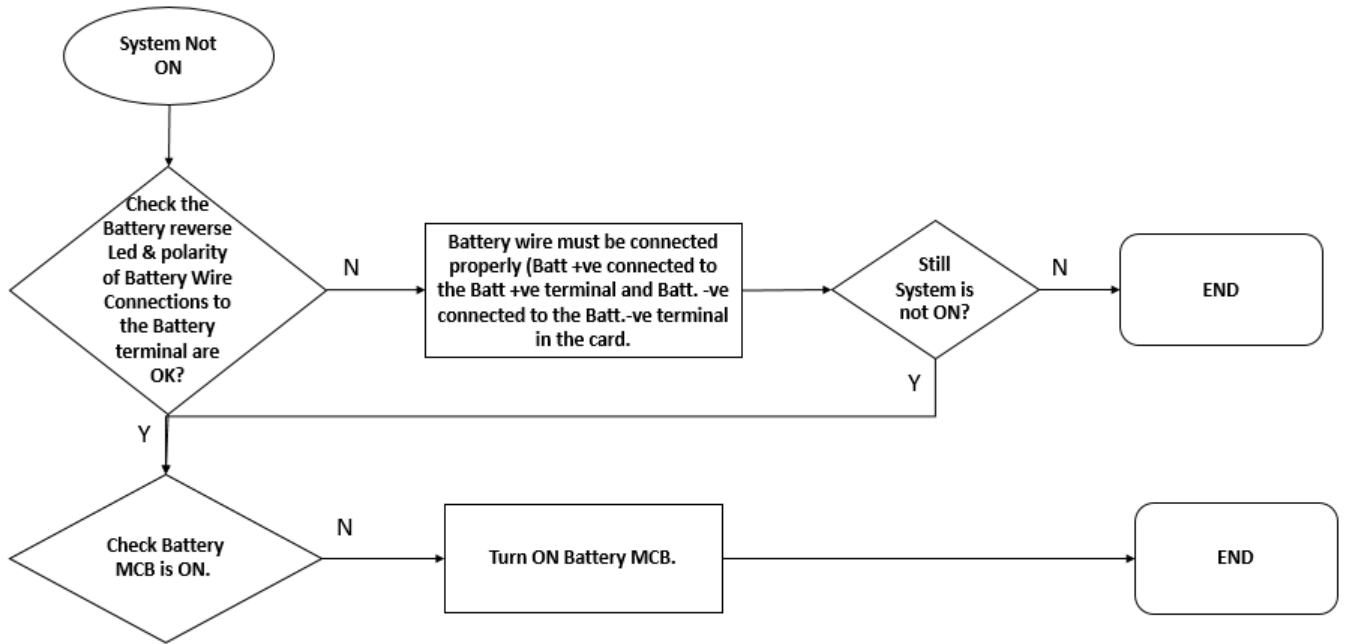

Condition: SYSTEM OVERLOAD

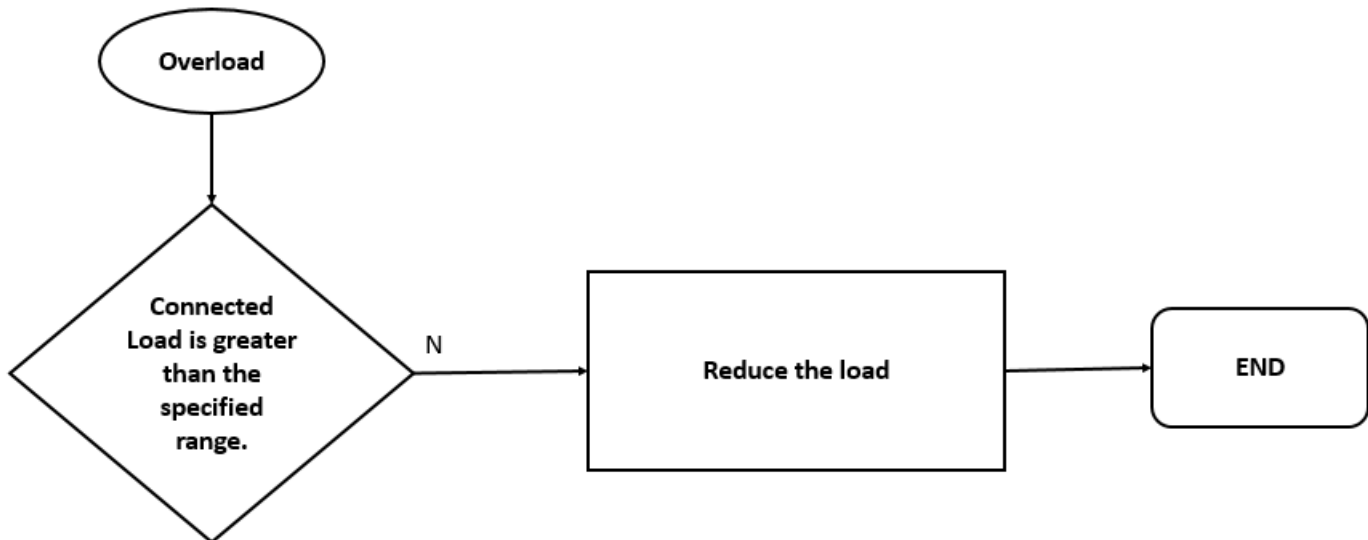

Condition: BATTERY NOT CHARGING BY SPV(No indication)

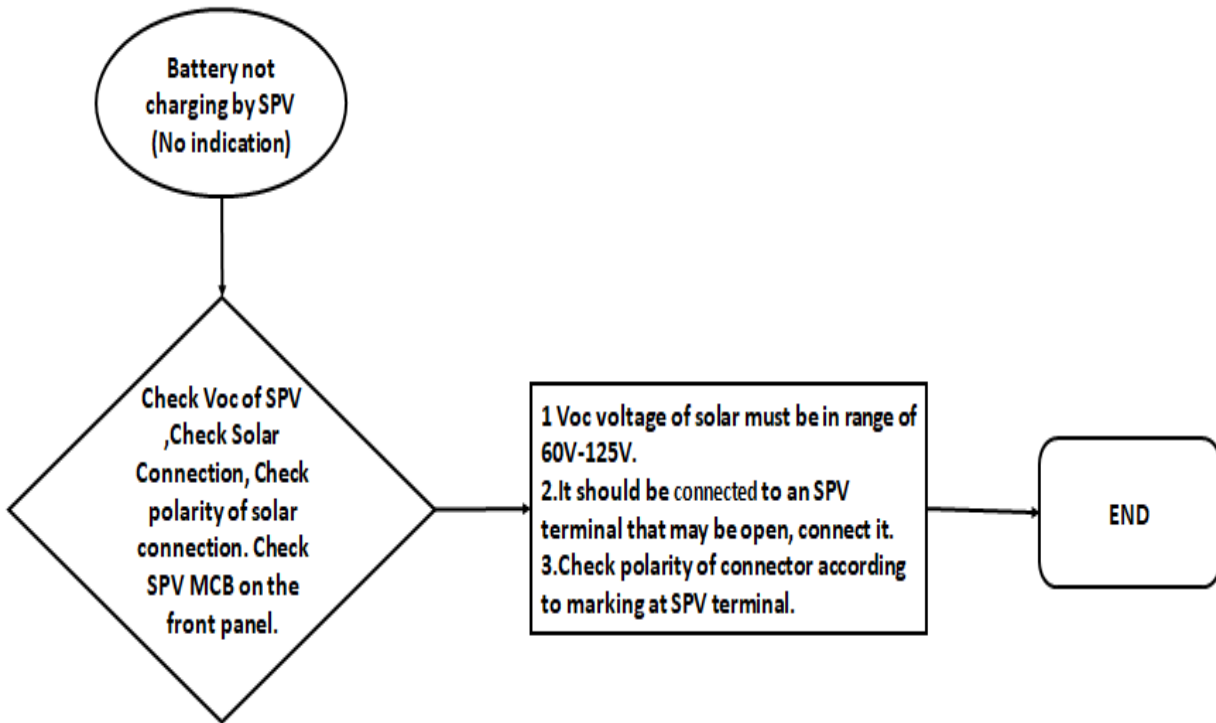

Condition: BATTERY NOT CHARGING BY SPV(PV Charge indication)

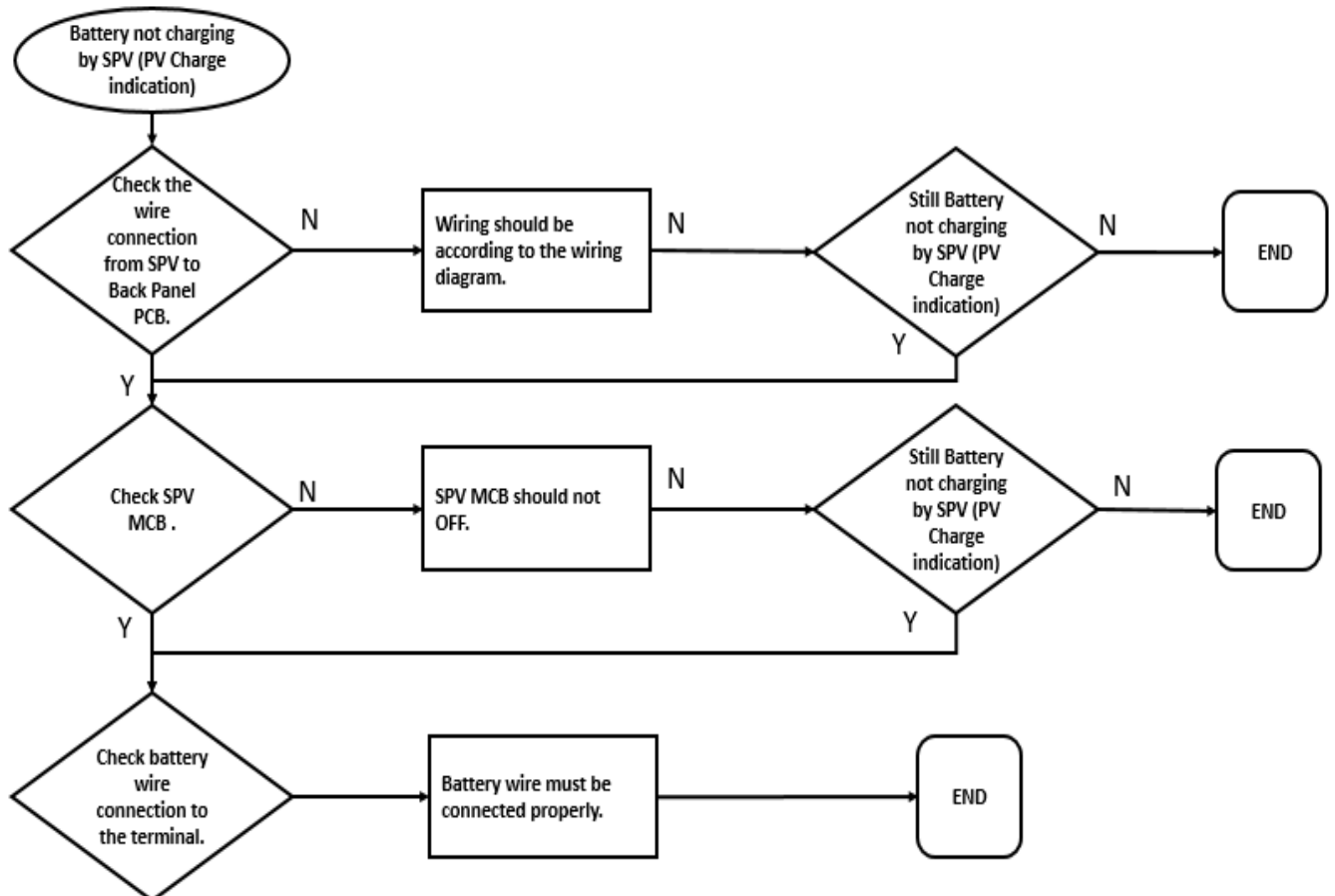

Condition: BATTERY NOT CHARGING BY MAINS(No indication)

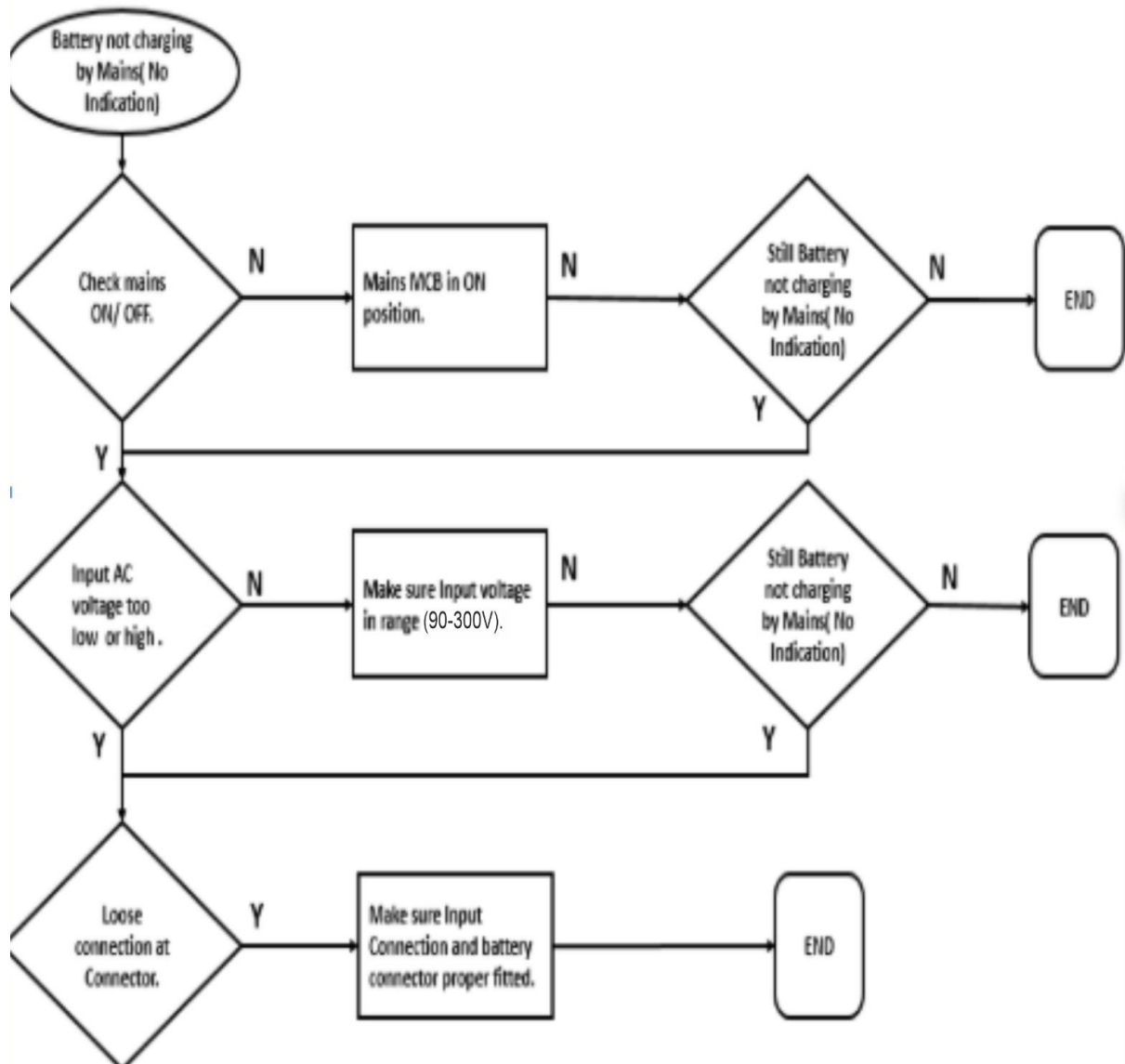

Condition: BATTERY NOT CHARGING BY MAINS(Mains Charging indication)

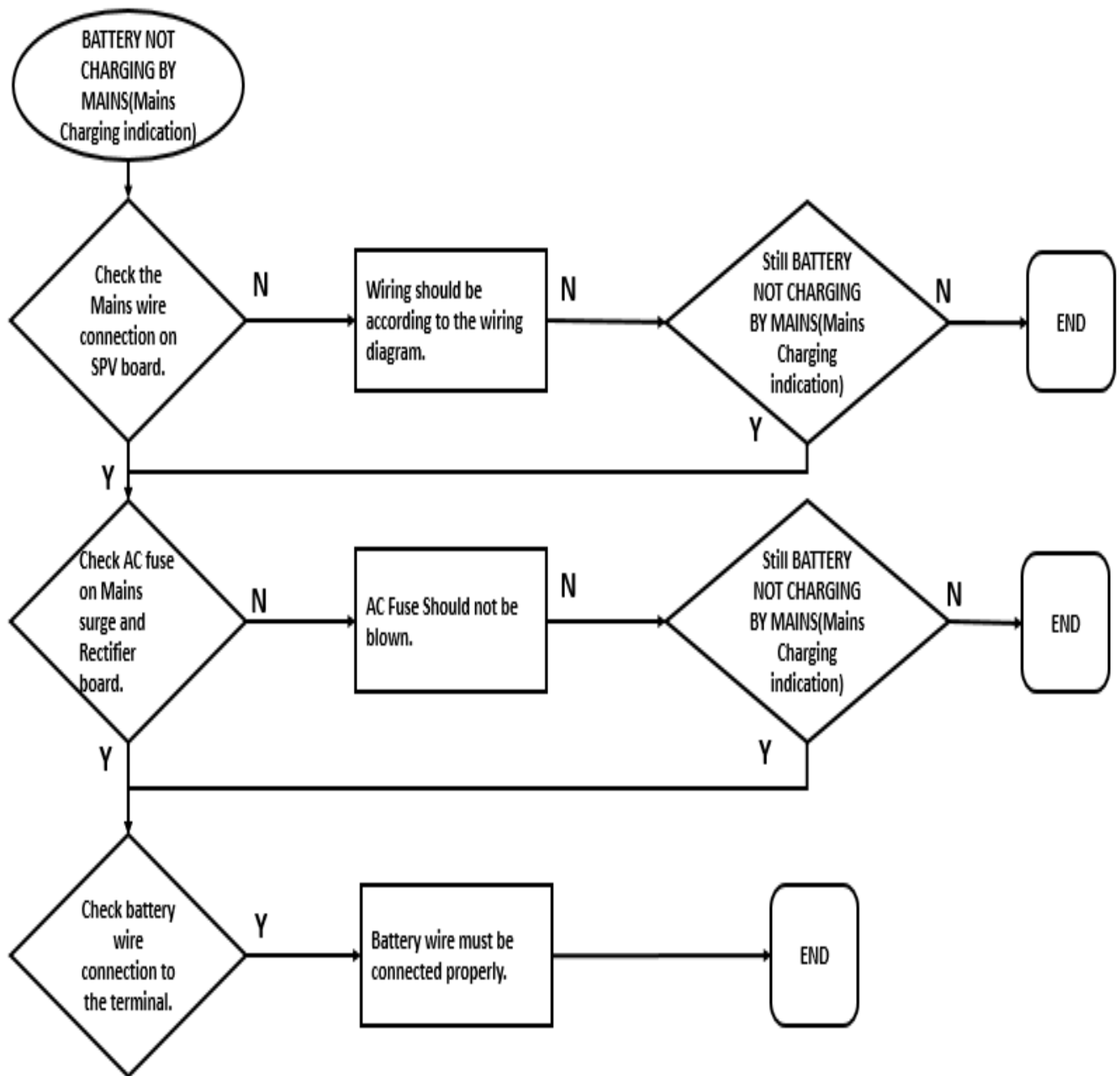

6. CONTROL ADJUSTMENT AND SERVICE

This section contains circuit board removal and replacement procedures.



CAUTION: Incorrect service or replacement of parts can result in severe personal injury and/or equipment damage. Service personnel must be trained and experienced to perform electrical and mechanical service.

6.1 MODULE REMOVAL/REPLACEMENT

Circuit Board Removal Safety Precautions

To prevent circuit board damage due to electrostatic discharge (ESD), a grounding wrist strap must be worn when handling circuit boards or socket-mounted IC's. (The wrist strap does not provide a direct short to ground, but is typically rated at approximately 1 megohm to ground.)

Attach the clip to the chassis ground screw in the cabinet and place the strap around your wrist before handling a circuit board.



CAUTION: Electrostatic discharge will damage circuit boards. Always wear a grounding wrist strap when handling circuit boards or socket-mounted IC's.

Steps to remove the Rectifire /MPPT/Inverter Module



- Disconnect all the connectors and wires from the circuit board as shown in step.
- Remove all screws from the edges of the Main PCB, after that uplift the Main card to remove it.

7. LIST OF SERVICEABLE PARTS:

Sr.No.	Component	MAKE	Part No.	Source of Procurement
1.	AC BREAKER 32A 1 POLE	C&S	—	Fujiyama Power

2.	INVERTER AC INPUT BREAKER 16A, 1POLE	C&S	—	Systems. Ltd.
3.	BATTERY DC BREAKER 40A, 1 POLE	C&S	—	
4.	SOLAR DC BREAKER 32A, 1 POLE	C&S	---	

8. TESTING POINTS AND TESTING PROCEDURE

Visual inspection :-

- Wiring of the system should be according to the wiring Diagram.
- Check wiring color coding according to the wiring diagram.
- Check all connectors should be connected properly at desired/specified location according to the wiring diagram.

Main wiring connections are as follows :-

- CONNECT AC MAINS 220V.
- **Mains Line & Neutral should be properly connected (use 16A plug & Socket) and line and Neutral check by electrical tester and line should be right side in socket.**
- CONNECT Solar leads to solar input(Nominal Voc = 60-120V). The solar panel will be in Series.
- CONNECT Inverter output terminal leads to Ac load .
- CONNECT Battery RJ45 cable to HUPS RJ45 Connector to the system.

CHECK POINTS

CHECK ON AC MAINS:-

- When AC I/P is connected, RECT ON LED should Glow Solid & display will be ON
- Now Check FC Charger Output voltage at the V_Load terminal(Battery is not connected) by removing the battery connector. No Load Output voltage should be 54V.
- Check Mains Voltage which is shown in system parameter window
- BATT. CHR.G. WARNING LED is ON.
- Now turn ON Battery (Connect battery wire connector) and check Battery Charging Current with display charging current.

CHECK on Solar alone:-

- Now connect Solar Input at solar connector and Solar CHG. LED(yellow) should glow solid when solar charge controller output comes.
- Check Solar Voltage at display Solar Voltage.
- Now turn on the battery and check Solar current with display Solar current.

CHECK on Solar and MAINS both:-

- Now Connect Solar and Mains both, check charging from solar should take priority than Mains according to the below table.
- **Check Solar CHG. LED and FC CHG. LED glow according to the below table:**

COMMUNICATION DETAILS:

- The HUPS with the SPV shall have provision for RS485 port for remote control and monitoring the health of the SPV system based on various parameters like battery charging current, Load current, Load and battery voltage, mains input voltage and other values. These parameters shall be recordable and available at EMS (NMS) for monitoring.

Protection test

- **Battery reverse- Before this test, Please make sure AC mains or Solar charger input should not be connected to the system.**
Connect Batt. +ve to Batt. negative terminal and Batt. -ve to Batt. positive terminal, Batt. reverse LED glow and no damage occurs in the card.
- **Solar reverse-** When Solar is reverse connected, Solar CHG. LED OFF and charging through solar is OFF.
- **Load Short circuit-** check load short circuit protection of the system by shorting the output(load) terminal of the system. The system goes into short-circuit protection in 30 sec.

9. PERIODICAL MAINTENANCE CHECK

We recommend periodic maintenance of the system by an authorized service engineer. Following are the guidelines for the same.

Please ensure ventilation and cleanliness in the environment surrounding the product.

We strictly recommend to keep Battery temperature at about 30°C(±5°C), for the better life cycle of the batteries.

Check points:-

	CHECK POINT	Monthl y	Quarterl y	Yearl y
1	Check Electrical connections for tightness on terminals.			✓
2	Battery connectors for tightness			✓
3	Verify the input, Output, Solar cabling and its terminations			✓
4	Cleaning of the dust on the front and back side.	✓		
5	Open the system and check all cable connections			✓

6	Working conditions of product.			✓
7	Physical condition of AC and DC capacitors			✓
8	Clean the Dust in the system.		✓	

10. TECHNICAL SPECIFICATIONS

Unit Model No. HUPS 500				
Electrical Characteristics (Input Rectifier)	Rectifier Model No.		FR4825	
	Item	Unit	Specification	
		Rated power	A	48V/25A (each), Hot standby operation
		Rated AC input voltage	Vac	230Vac (single phase)
		Input voltage range	Vac	90-300Vac
		Frequency	Hz	50Hz (tolerance: 47Hz ~ 53Hz)
		Power factor	kW/kVA	>0.98 (0.95) full load(half load)
		Efficiency	%	>95% (full load)
		Harmonic distortion	THDV%	<5 % (full load)
		Ripple and Noise		<300mV p-p
		No. of Rectifier module	No.	2
		Rectifier module configuration	-	Hot stand by
		Protection		Output short circuit protection Overload Protection O/P low / high protection Over temperature protection
		Alarm		Mains Over or Under Voltage Mains Over voltage Disconnection High Ambient Temperature Short on output from outside
		LED Indications		RECT ON/Green ALARM/Yellow FAULT/Red

	Cooling		Fan (front to back airflow)
	Fan Speed		Temperature and output current Regulated
	Operating Temp		-5°C to +50°C ,upto 75°C with de-rating
	Storage Temp.		-40°C to +85°C
	Humidity		Operating: ≤95% non-condensing storage: ≤99% non-condensing
Electrical Characteristics (Inverter)	Inverter Model No.		FI500
	Rated power	VA	500 VA
	Rated AC Output voltage	Vac	230Vac +/-1%
	Frequency	Hz	50Hz
	Overload	%	105%-125%, 180 sec 126%-150%, 30 sec Recovery at 90% Load
	Power Factor	kW/kVA	0.8 to 1
	Crest Factor		3 : 1
	Peak Efficiency	%	> 90%
	Voltage Harmonics	THDV%	<3% (Linear load)
	Protection		Output short circuit protection Overload Protection Battery low / high protection Over temperature protection
	Audible Warning		Overload Battery low protection Over temperature protection
	LED Indications		INV ON/Green Warning/Yellow FAULT/Red
	Batt. low (V)	Alarm	46 V
		Low Cut	44 V
		Auto Low Recovery	48 V
Batt. High	Alarm	55 V	
	High Cut	56 V	
	Auto High Recovery	54V	

	Over Temperature	Alarm	70°C
		High temp cut	80°C
		Recovery	60°C
	User Interface	LCD Display	YES
		LED Indications	Yes
	Isolation	DC to AC	2.2KV
	Cooling	forced	yes
	Environmental Conditions	Operating Temp.	-5°C to +50°C ,upto 75°C with de-rating"
		Storage Temp	-40°C to +85°C
	Electrical Characteristics (MPPT Solar Charge controller)	MPPT Model No.	
MPPT rating		Pmax	1KW
Voc (max)		Voc	120Vdc
Solar Low cut		Vdc	60V
Solar High cut		Vdc	120V
Efficiency *		%	>93%
Protection			Output short circuit protection Overload Protection Solar low / high protection Over temperature protection
Over Temperature		Alarm	70°C
		High temp cut	80°C
		Recovery	60°C
LED Indications			SOLAR ON/ Green Alarm /Yellow FAULT/Red
User Interface		LCD Display	Yes
		Communication	RS485, Ethernet
Cooling		Fan (front to back airflow)	

	Fan Speed		Temperature and output current Regulated
	Environmental Conditions	Operating Temp.	-5°C to +50°C ,upto 75°C with de-rating"
		Storage Temp	-40°C to +85°C
Communications	Interface	Protocol	Ethernet /SNMP (Optional), additional RS485 port for external communication
		Supported Network	LAN
		Features	Monitoring system parameters and alarms
	Optional Interface		GSM 2G, 4G
	Battery	Li Ion	Digital Interlocking via RS485 ,Anti-theft protection
	Dimensions	System	(LxDxH) mm
Configuration			Modular (DSCA, Rectifier, MPPT, Inverter)
Mounting			19" Rack Mount